

REVISIONS		DATE	APPROVED
ZONE	REV.	DESCRIPTION	

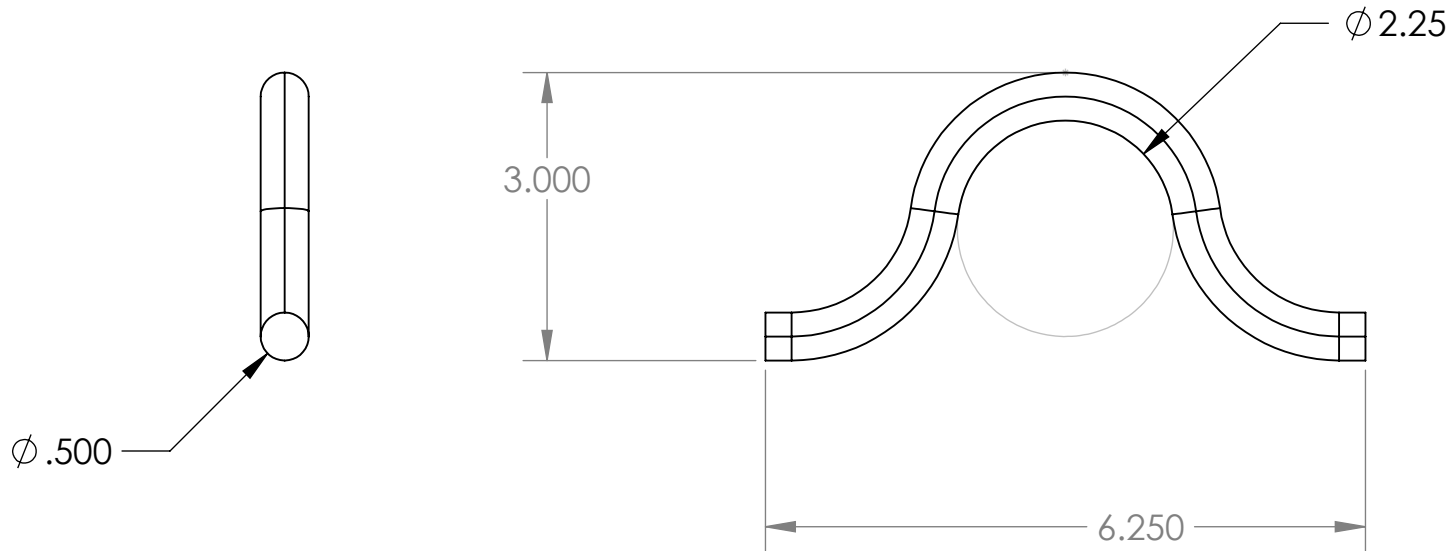

PROPRIETARY AND CONFIDENTIAL
 THE INFORMATION CONTAINED IN THIS DRAWING IS THE SOLE PROPERTY OF MAD DOG METAL INC. ANY REPRODUCTION IN PART OR AS A WHOLE WITHOUT THE WRITTEN PERMISSION OF MAD DOG METAL INC. IS PROHIBITED.

		UNLESS OTHERWISE SPECIFIED:	NAME	DATE
		DIMENSIONS ARE IN INCHES	DRAWN	RM
		TOLERANCES:	CHECKED	8/3/2016
		FRACTIONAL ±	ENG APPR.	
		ANGULAR: MACH ± BEND ±	QUANTITY:	
		TWO PLACE DECIMAL ±	COMMENTS:	
		THREE PLACE DECIMAL ±		
		INTERPRET GEOMETRIC TOLERANCING PER:		
		MATERIAL		
		FINISH		
NEXT ASSY	USED ON			
APPLICATION		DO NOT SCALE DRAWING		

MAD DOG METAL INC		
TITLE:		
Pipe Steel Loop		
SIZE	DWG. NO.	REV
A		
SCALE:	Weight lb	SHEET 1 OF 1

5

4

3

2

1